



**GIOVENZANA
INTERNATIONAL B.V**

AUTOMATION TECHNOLOGIES



AUTOMATION

GENERAL CATALOGUE

GIOVENZANA INTERNATIONAL reserves the right to modify, in order to improve their performance, all technical and functional characteristics of the products shown in the catalogue without prior notice as this information is intended for general knowledge and is not legally binding.

Limit Switches

FA - FT - FT1R - Safety - FCT - FCM - Astra Series

Table of contents



AUTOMATION TECHNOLOGIES



Thermoplastic and die-cast aluminium limit switches



Limit switches with reset



Safety limit switches



Pre-wired thermoplastic limit switches

TABLE OF CONTENTS

■ Introduction	pag. 100	■ Installation and use	pag. 119
■ FA Series limit switches	pag. 102	■ Technical data	pag. 120
■ FT Series limit switches	pag. 108	■ FCT - FCM Series limit switches	pag. 121
■ Safety limit switches with reset	pag. 115	■ Pre-wired	
■ Safety limit switches	pag. 117	■ Astra universal limit switches	pag. 123

Limit Switches

FA - FT - FT1R - Safety - FCT - FCM - Astra Series

Terminology

DOUBLE INSULATION □

Materials of group II, according to IEC536, are made with double insulation. This consists of doubling the insulation capability by means

of an additional divider in order to eliminate any electrical shock risk and avoid the need for any additional protections.

APERTURA POSITIVA ⊕

A limit switch complies to this specification when all the normally closed contact elements of the switch can be changed, with certainty, to the open position (no flexible link between the moving contacts and the operator of the switch, to which an actuating force is applied). Positive opening does not apply to NO contacts. Control switches

with positive opening operation can be equipped with either slow-break or snap-action contacts. In order to use different contacts on the same switch, it is necessary to electrically separate them; otherwise only one contact can be used. Every positive opening control switch must be marked on the external housing with the symbol. ⊕

CONTACT ELEMENTS ACTING INDEPENDENTLY (OR SNAP ACTION)

Is defined, under IEC947-5-1/EN6094-5-1, the contact element of a device for manual or automatic control circuits where the speed of motion of the contact is virtually independent of the speed of motion of the actuator. Commonly called "quick trigger" the electrical behavior of these elements means that the contact is in order even in the slow movements of the actuator. These contact elements have position does not coincide with the release of drive (differential stroke) See example page. 105.

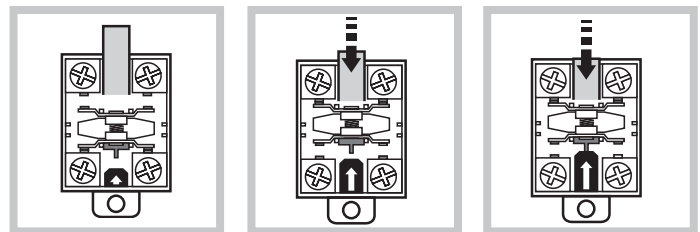

Contacto a riposo

Contacto azionato

Apertura positiva

CONTACT ELEMENTS DIRECT ACTING (OR SLOW ACTION)

Is defined, under IEC947-5-1/EN6094-5-1, the contact element of a device for manual or automatic control circuits where speed of movement of the contact depends on the speed of motion of the actuator. See example page. 105

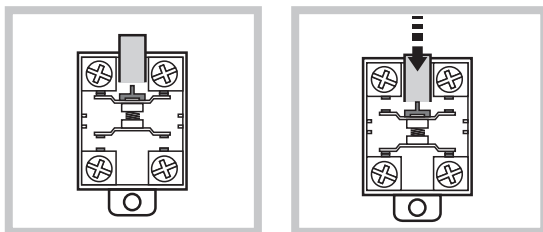

Contact in stand-by

Contact activated

CONTACT BLOCKS CONFIGURATION

ACCORDING TO IEC/EN60947-5-1

Contact blocks with 4 terminals must be marked with Za or Zb symbols as shown in the picture below.

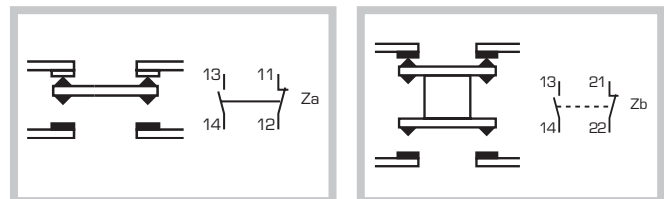

Contacts with same polarity

The two moving contacts are electrically insulated

APPLICATIONS

AC-15: control of an electromagnet on a.c., test 10 le/le.

AC-13: control of an electromagnet on d.c., test le/le.

TERMINALS

For limit switches with metal housing, the fixing point of the earth conductor must be marked and must be positioned inside the housing next to the cable entry.

Limit Switches

FA - FT - FT1R - Safety - FCT - FCM - Astra Series
Terminology



AUTOMATION TECHNOLOGIES

MINIMUM OPENING FORCE/MOMENTUM

It is the minimum force/momentum that must be applied by the actuator for the contacts to trip.

MINIMUM POSITIVE OPENING FORCE/MOMENTUM

It is the minimum force/momentum that must be applied by the actuator to guarantee the positive opening of NC contacts.

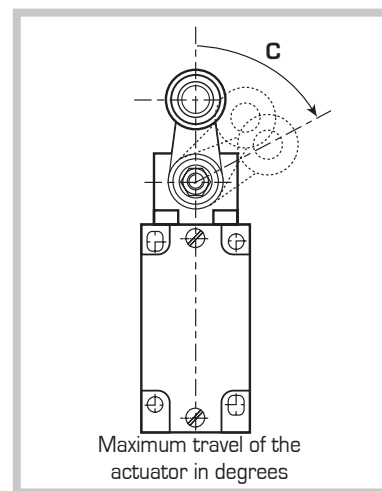
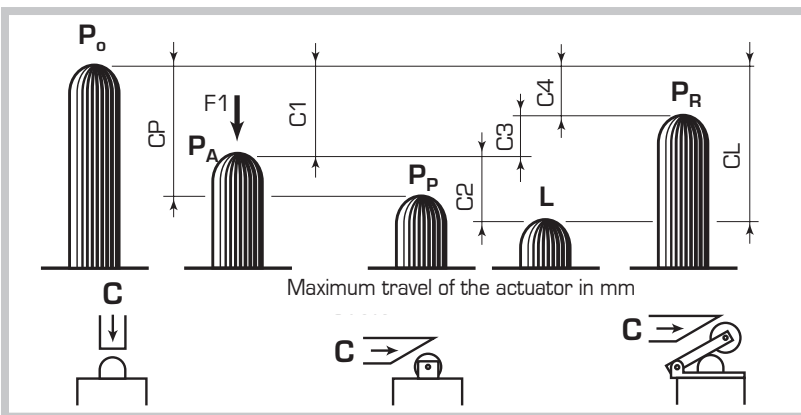

- P_o** Rest position
Position of the actuator when no external force is applied.
- P_A** Tripping point of contact
Position of the actuator, with force F1 applied, in which the contacts leave the stand-by position.
- P_p** Positive opening position
Position of the actuator when there is positive opening.
- L** Maximum travel position
Maximum travel of the actuator when the force F1 is applied.
- P_R** Resetting position
Position of the actuator when the contacts are back in their non actuated position.

- C₁** Tripping travel
Distance between the P_o and P_A positions.
- C_p** Positive opening tripping travel
Minimum travel of the actuator from the P_o position to guarantee positive opening of NC contacts.
- C₂** Extra tripping travel
Distance between P_A and the maximum travel L.
- C₁** Maximum travel
Distance between P_o and the maximum travel L.
- C₃** Differential travel (C₁-C₄)
Distance between P_A and P_R
- C₄** Resetting travel
Distance between P_R and P_o

Maximum travel of the actuator in degrees
Tripping travel for snap-action contacts

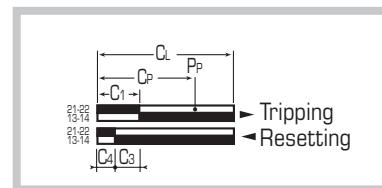

Tripping travel for slow-break contacts

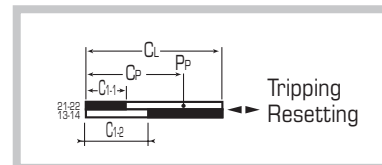

NOTE: for slow-break contacts, C3=01, C1-1=Tripping and resetting travel of contacts 21-22, C1-2= Tripping and resetting travel of contacts 13-14

Examples

FA134Z11
(snap-action contacts)



Tripping travel in mm/
cam linear movement

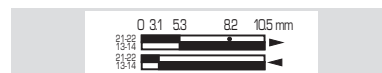

FA138Z11
(snap-action contacts)

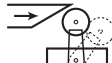

Tripping travel in degrees/
lever rotary movement



FA131X11
(slow break contacts)



Tripping travel in mm/
plunger linear movement

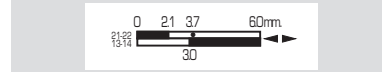

Limit Switches

FA1 Series

IP66 die-cast aluminium type

1 cable entry
M16x1.5



FA131



FA134



FA132



FA133

TYPE OF OPERATOR	SHORT STEEL END PLUNGER	STEEL ROLLER PLUNGER	ROLLER LEVER PLUNGER HORIZONTAL ACTUATION	ROLLER LEVER PLUNGER VERTICAL ACTUATION
Standard - Positive opening NC contacts	EN50047	EN50047	-	-
Minimum tripping force	15	12	7	7
Minimum positive opening force	30	30	24	24
Z11 1NC-1NO Snap action Zb	FA131Z11 0 13 25 41 56 mm	FA134Z11 0 25 47 76 96 mm	FA132Z11 0 49 90 145 210 mm	FA133Z11 0 49 90 145 210 mm
X11 1NC-1NO Slow break Zb	FA131X11 0 16 32 56 mm 2.5	FA134X11 0 32 60 96 mm 46	FA132X11 0 60 105 210 mm 86	FA133X11 0 60 105 210 mm 86
Y11 1NC-1NO overlapping Slow break Zb	FA131Y11 0 29 45 56 mm 15	FA134Y11 0 53 82 96 mm 30	FA132Y11 0 102 146 210 mm 54	FA133Y11 0 102 146 210 mm 54
Z02 2NC Snap action Zb	FA131Z02 0 13 24 40 56 mm	FA134Z02 0 25 45 74 96 mm	FA132Z02 0 51 86 131 210 mm	FA133Z02 0 51 86 131 210 mm
W02 2NC Slow break Zb	FA131W02 0 15 31 56 mm	FA134W02 0 30 59 96 mm	FA132W02 0 57 102 210 mm	FA133W02 0 57 102 210 mm
W20 2NO Slow break Zb	FA131W20 0 14 56 mm	FA134W20 0 28 96 mm	FA132W20 0 5.3 210 mm	FA133W20 0 5.3 210 mm
WEIGHT gr - MIN. PACK QTY.	168 gr 1 pcs	175 gr 1 pcs	186 gr 1 pcs	186 gr 1 pcs

DIMENSIONS

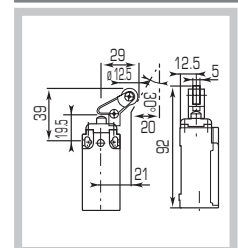
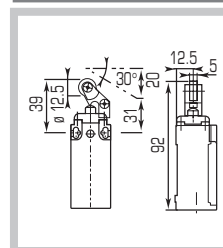
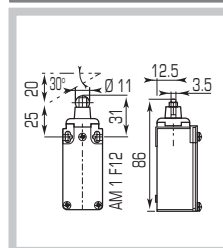
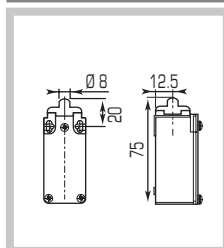
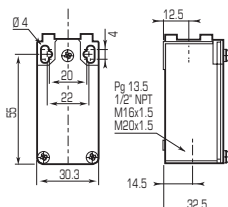

Limit Switches

FA1 Series

IP66 die-cast aluminium type



AUTOMATION TECHNOLOGIES

1 cable entry
M16x1.5



FA138



FA141



FA139



FA140

TYPE OF OPERATOR	ROLLER LEVER Ø 18	RUBBER ROLLER LEVER Ø 50	VARIABLE LENGTH ROLLER LEVER Ø 18	VARIABLE LENGTH RUBBER ROLLER LEVER Ø 50
Standard - Positive opening NC contacts	-	-	-	-
Minimum tripping force	0.10	0.10	0.10	0.10
Minimum positive opening force	0.32	-	-	-
Z11 Snap action 1NC-1NO	FA138Z11 	FA141Z11 	FA139Z11 	FA140Z11
X11 Slow break 1NC-1NO	FA138X11 	FA141X11 	FA139X11 	FA140X11
Y11 Slow break 1NC-1NO overlapping	FA138Y11 	FA141Y11 	FA139Y11 	FA140Y11
Z02 Snap action 2NC	FA138Z02 	FA141Z02 	FA139Z02 	FA140Z02
W02 Slow break 2NC	FA138W02 	FA141W02 	FA139W02 	FA140W02
W20 Slow break 2NO	FA138W20 	FA141W20 	FA139W20 	FA140W20

WEIGHT gr - MIN. PACK QTY.

235 gr 1 pcs 255 gr 1 pcs 245 gr 1 pcs 265 gr 1 pcs

DIMENSIONS

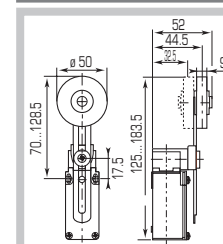
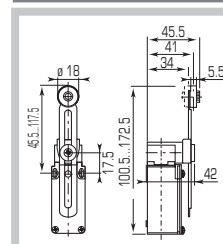
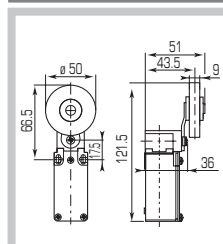
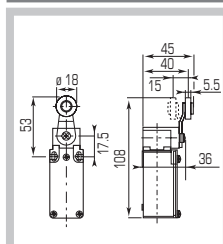
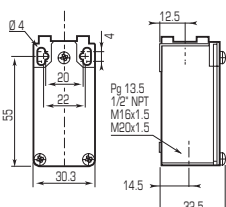

Limit Switches

FA1 Series

IP66 die-cast aluminium type

1 cable entry
M16x1.5



FA135



FA136



FA137

TYPE OF OPERATOR	SPRING LEVER WITH TIP IN PA	"CAT'S WHISKER"	STEEL ROD LEVER Ø 3
Standard - Positive opening NC contacts	-	-	-
Minimum tripping force	0.10	0.10	0.10
Minimum positive opening force	-	-	-
Z11 1NC-1NO Snap action Zb	FA135Z11 	FA136Z11 	FA137Z11
X11 1NC-1NO Slow break Zb	FA135X11 	FA136X11 	FA137X11
Y11 1NC-1NO Slow break overlapping Zb	FA135Y11 	FA136Y11 	FA137Y11
Z02 2NC Snap action Zb	FA135Z02 	FA136Z02 	FA137Z02
W02 2NC Slow break Zb	FA135W02 	FA136W02 	FA137W02
W20 2NO Slow break Zb	FA135W20 	FA136W20 	FA137W20

WEIGHT gr - MIN. PACK QTY.

235 gr 1 pcs

255 gr 1 pcs

245 gr 1 pcs

DIMENSIONS

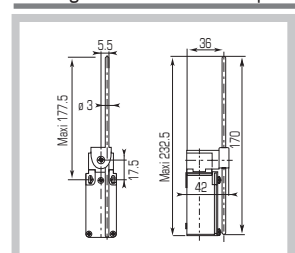
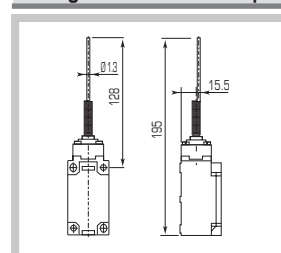
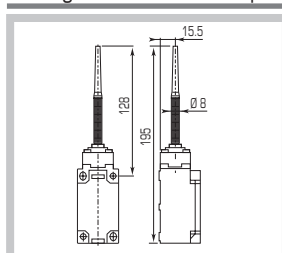
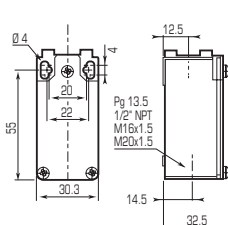

Limit Switches

FA3 Series

IP66 die-cast aluminium type



AUTOMATION TECHNOLOGIES

3 cable entries
M16x1.5



FA331



FA334



FA332

TYPE OF OPERATOR	SHORT STEEL END PLUNGER	SHORT STEEL ROLLER PLUNGER	ROLLER LEVER PLUNGER HORIZONTAL ACTUATION
Standard - Positive opening NC contacts	-	-	-
Minimum tripping force	15	12	7
Minimum positive opening force	30	30	24
Z11 1NC-1NO Snap action Zb	FA331Z11 	FA334Z11 	FA332Z11
X11 1NC-1NO Slow break Zb	FA331X11 	FA334X11 	FA332X11
Y11 1NC-1NO Slow break overlapping Zb	FA331Y11 	FA334Y11 	FA332Y11
Z02 2NC Snap action Zb	FA331Z02 	FA334Z02 	FA332Z02
W02 2NC Slow break Zb	FA331W02 	FA334W02 	FA332W02
W20 2NO Slow break Zb	FA331W20 	FA334W20 	FA332W20

WEIGHT gr - MIN. PACK QTY.

270 gr

1 pcs

280 gr

1 pcs

290 gr

1 pcs

DIMENSIONS

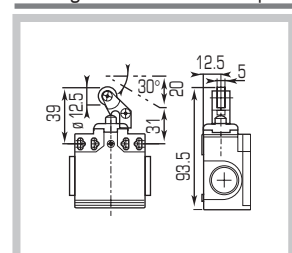
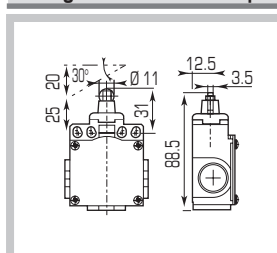
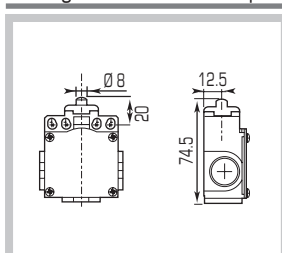
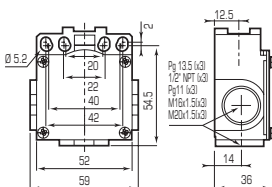

Limit Switches

FA3 Series

IP66 die-cast aluminium type



AUTOMATION TECHNOLOGIES

3 cable entries
M16x1.5



FA335



FA336

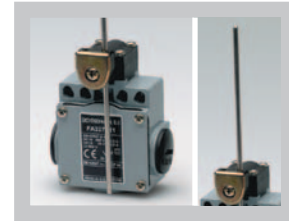

FA337

TYPE OF OPERATOR	SPRING LEVER WITH TIP IN PA	"CAT'S WHISKER"	VARIABLE LENGTH STEEL ROD LEVER Ø 3
Standard - Positive opening NC contacts	-	-	-
Minimum tripping force	0.10	0.10	0.10
Minimum positive opening force	-	-	-
Z11 1NC-1NO Snap action Zb	FA335Z11 	FA336Z11 	FA337Z11
X11 1NC-1NO Slow break Zb	FA335X11 	FA336X11 	FA337X11
Y11 1NC-1NO Slow break overlapping Zb	FA335Y11 	FA336Y11 	FA337Y11
Z02 2NC Snap action Zb	FA335Z02 	FA336Z02 	FA337Z02
W02 2NC Slow break Zb	FA335W02 	FA336W02 	FA337W02
W20 2NO Slow break Zb	FA335W20 	FA336W20 	FA337W20

WEIGHT gr - MIN. PACK QTY.

305 gr 1 pcs

320 gr 1 pcs

380 gr 1 pcs

DIMENSIONS

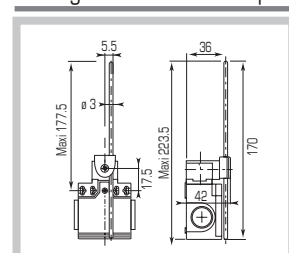
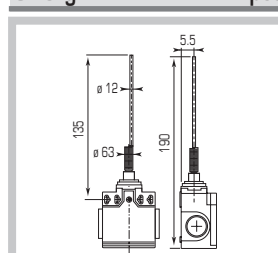
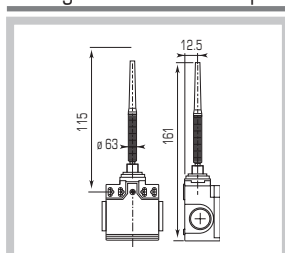
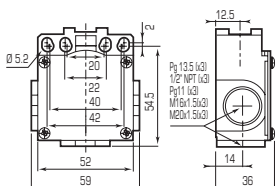

Limit Switches

FT1 Series

IP65 □ thermoplastic type

1 cable entry
M16x1.5



FT131



FT1P31



FT134



FT132

TYPE OF OPERATOR	SHORT STEEL END PLUNGER	SHORT STEEL END PLUNGER WITH PROTECTIVE BOOT	ROLLER LEVER PLUNGER	ROLLER LEVER PLUNGER HORIZONTAL ACTUATION
Standard - Positive opening NC contacts	EN50047	EN50047	EN50047	EN50047
Minimum tripping force	15	15	12	7
Minimum positive opening force	30	30	30	24
Z11 Snap action 1NC-1NO Zb	FT131Z11 	FT1P31Z11 	FT134Z11 	FT132Z11
X11 Slow break 1NC-1NO Zb	FT131X11 	FT1P31X11 	FT134X11 	FT132X11
Y11 Slow break 1NC-1NO overlapping Zb	FT131Y11 	FT1P31Y11 	FT134Y11 	FT132Y11
Z02 Snap action 2NC Zb	FT131Z02 	FT1P31Z02 	FT134Z02 	FT132Z02
W02 Slow break 2NC Zb	FT131W02 	FT1P31W02 	FT134W02 	FT132W02
W20 Slow break 2NO Zb	FT131W20 	FT1P31W20 	FT134W20 	FT132W20

WEIGHT gr - MIN. PACK QTY.

60 gr 1 pcs

60 gr 1 pcs

62 gr 1 pcs

65 gr 1 pcs

DIMENSIONS

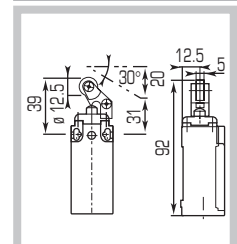
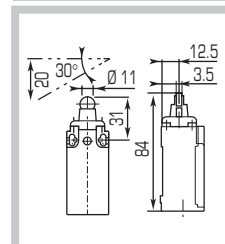
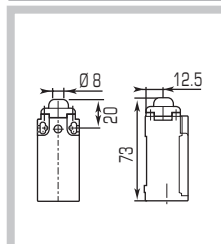
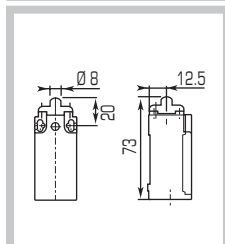
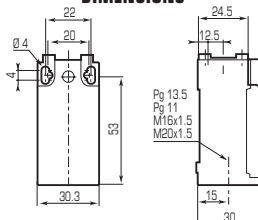

Limit Switches

FT1 Series

IP65 □ thermoplastic type



AUTOMATION TECHNOLOGIES

1 cable entry
M16x1.5



FT1P32



FT133



FT1P33



FT138

TYPE OF OPERATOR	ROLLER LEVER PLUNGER WITH PROTECTIVE BOOT HORIZONTAL ACTUATION	ROLLER LEVER PLUNGER VERTICAL ACTUATION	ROLLER LEVER PLUNGER WITH PROTECTIVE BOOT VERTICAL ACTUATION	ROLLER LEVER Ø 18
Standard - Positive opening NC contacts (→)	EN50047 (→)	EN50047 (→)	EN50047 (→)	EN50047 (→)
Minimum tripping force	N	7	7	0.10
Minimum positive opening force	N	24	24	0.32
Z11 Snap action 1NC-1NO	FT1P32Z11 0 49 90 145 210 mm	FT133Z11 0 49 90 145 210 mm	FT1P33Z11 0 49 90 145 210 mm	FT138Z11 0 17Y 31Y 47Y 74Y
X11 Slow break 1NC-1NO	FT1P32X11 0 60 105 210 mm 86	FT133X11 0 60 105 210 mm 86	FT1P33X11 0 60 105 210 mm 86	FT138X11 0 21Y 37Y 74Y 30Y
Y11 Slow break 1NC-1NO overlapping	FT1P32Y11 0 102 146 210 mm 54	FT133Y11 0 102 146 210 mm 54	FT1P33Y11 0 102 146 210 mm 54	FT138Y11 0 35° 51° 74° 18°
Z02 Snap action 2NC	FT1P32Z02 0 51 86 131 210 mm	FT133Z02 0 51 86 131 210 mm	FT1P33Z02 0 51 86 131 210 mm	FT138Z02 0 17 30 46 74
W02 Slow break 2NC	FT1P32W02 0 57 102 210 mm	FT133W02 0 57 102 210 mm	FT1P33W02 0 57 102 210 mm	FT138W02 0 19 37 74
W20 Slow break 2NO	FT1P32W20 0 5.3 210 mm	FT133W20 0 5.3 210 mm	FT1P33W20 0 5.3 210 mm	FT138W20 0 18Y 74Y

WEIGHT gr - MIN. PACK QTY.

65 gr 1 pcs 65 gr 1 pcs 65 gr 1 pcs 80 gr 1 pcs

DIMENSIONS

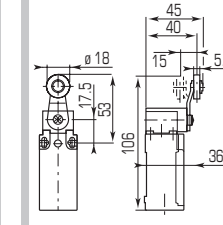
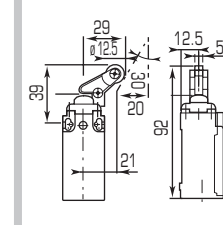
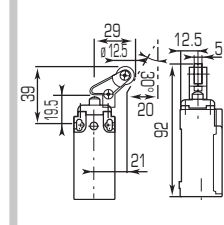
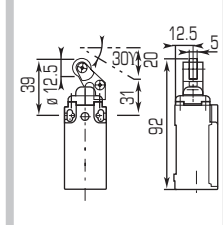
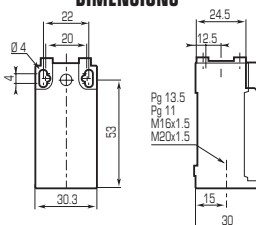

Limit Switches

FT1 Series

IP65 □ thermoplastic type

1 cable entry
M16x1.5



FT141



FT139

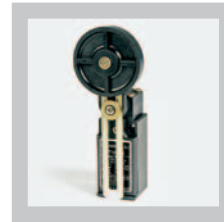

FT140

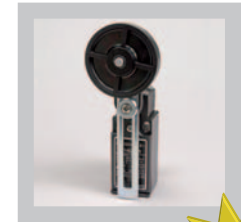

FT140R



TYPE OF OPERATOR	RUBBER ROLLER LEVER Ø 50	VARIABLE LENGTH ROLLER LEVER Ø 18	VARIABLE LENGTH RUBBER ROLLER LEVER Ø 50	VARIABLE LENGTH AND RUBBER ROLLER LEVER Ø 50
Standard - Positive opening NC contacts (→)	-	-	-	-
Minimum tripping force	N	0.10	0.10	0.10
Minimum positive opening force	N	-	-	-
Z11 Snap action 1NC-1NO	FT141Z11 	FT139Z11 	FT140Z11 	FT140Z11R
X11 Slow break 1NC-1NO	FT141X11 	FT139X11 	FT140X11 	FT140X11R
Y11 Slow break 1NC-1NO overlapping	FT141Y11 	FT139Y11 	FT140Y11 	FT140Y11R
Z02 Snap action 2NC	FT141Z02 	FT139Z02 	FT140Z02 	FT140Z02R
W02 Slow break 2NC	FT141W02 	FT139W02 	FT140W02 	FT140W02R
W20 Slow break 2NO	FT141W20 	FT139W20 	FT140W20 	FT140W20R

WEIGHT gr - MIN. PACK QTY.

95 gr 1 pcs

105 gr 1 pcs

125 gr 1 pcs

125 gr 1 pcs

DIMENSIONS

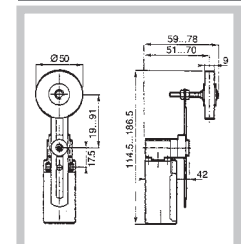
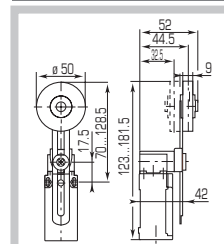
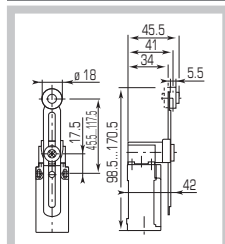
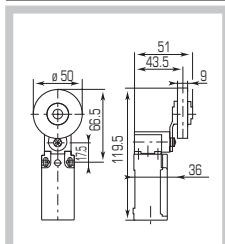
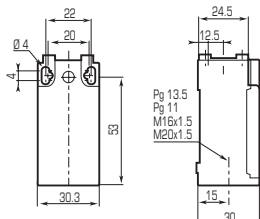

Limit Switches

FT1 Series

IP65 thermoplastic type



AUTOMATION TECHNOLOGIES

1 cable entry
M16x1.5



FT135



FT136



FT137

TYPE OF OPERATOR	SPRING LEVER WITH TIP IN PA	"CAT'S WHISKER"	VARIABLE LENGTH STEEL ROD LEVER Ø 3
Standard - Positive opening NC contacts	EN50047	-	-
Minimum tripping force	0.12	0.12	0.12
Minimum positive opening force	-	-	-
Z11 Snap action 1NC-1NO	FT135Z11 	FT136Z11 	FT137Z11
X11 Slow break 1NC-1NO	FT135X11 	FT136X11 	FT137X11
Y11 Slow break 1NC-1NO overlapping	FT135Y11 	FT136Y11 	FT137Y11
Z02 Snap action 2NC	FT135Z02 	FT136Z02 	FT137Z02
W02 Slow break 2NC	FT135W02 	FT136W02 	FT137W02
W20 Slow break 2NO	FT135W20 	FT136W20 	FT137W20

WEIGHT gr - MIN. PACK QTY.

70 gr 1 pcs

80 gr 1 pcs

105 gr 1 pcs

DIMENSIONS

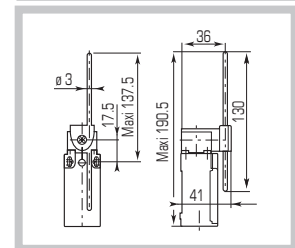
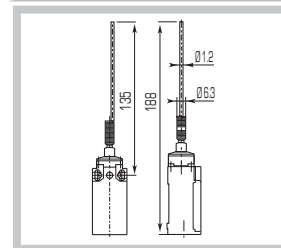
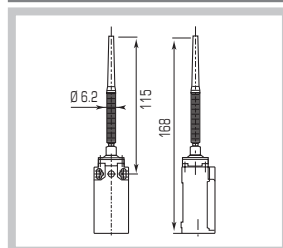
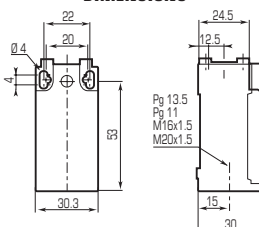

Limit Switches

FT2 Series

IP65 □ thermoplastic type

2 cable entry
M16x1.5



FT231



FT2P31



FT234



FT232

TYPE OF OPERATOR	SHORT STEEL END PLUNGE	SHORT STEEL END PLUNGER WITH PROTECTIVE BOOT	ROLLER LEVER PLUNGER	ROLLER LEVER PLUNGER HORIZONTAL ACTUATION
Standard - Positive opening NC contacts (→)	- (→)	- (→)	- (→)	- (→)
Minimum tripping force N	15	15	12	7
Minimum positive opening force N	30	30	30	24
Z11 Snap action 1NC-1NO	FT231Z11 0 13 25 41 56 mm	FT2P31Z11 0 13 25 41 56 mm	FT234Z11 0 25 47 76 96 mm	FT232Z11 0 49 90 145 210 mm
X11 Slow break 1NC-1NO	FT231X11 0 16 32 56 mm 2.5	FT2P31X11 0 16 32 56 mm 2.5	FT234X11 0 32 60 96 mm 46	FT232X11 0 60 105 210 mm 86
Y11 Slow break 1NC-1NO overlapping	FT231Y11 0 29 45 56 mm 1.5	FT2P31Y11 0 29 45 56 mm 1.5	FT234Y11 0 53 82 96 mm 30	FT232Y11 0 102 146 210 mm 54
Z02 Snap action 2NC	FT231Z02 0 13 24 40 56 mm	FT2P31Z02 0 13 24 40 56 mm	FT234Z02 0 25 45 74 96 mm	FT232Z02 0 51 86 131 210 mm
W02 Slow break 2NC	FT231W02 0 15 31 56 mm	FT2P31W02 0 15 31 56 mm	FT234W02 0 30 59 96 mm	FT232W02 0 57 102 210 mm
W20 Slow break 2NO	FT231W20 0 14 56 mm	FT2P31W20 0 14 56 mm	FT234W20 0 28 96 mm	FT232W20 0 5.3 210 mm

WEIGHT gr - MIN. PACK QTY.

100 gr 1 pcs

100 gr 1 pcs

105 gr 1 pcs

105 gr 1 pcs

DIMENSIONS

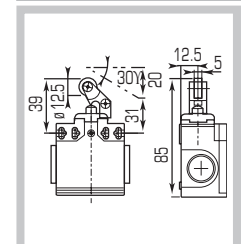
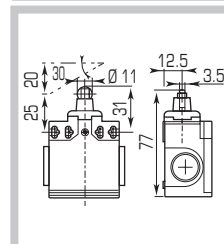
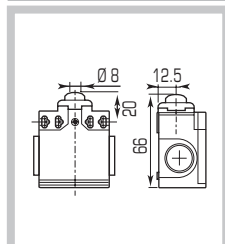
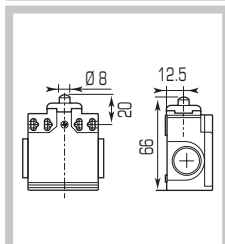
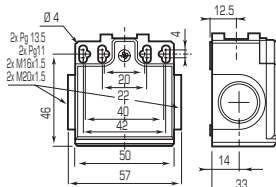

Limit Switches

FT2 Series

IP65 □ thermoplastic type



AUTOMATION TECHNOLOGIES

2 cable entry
M16x1.5



FT2P32



FT238



FT239



FT240

TYPE OF OPERATOR	ROLLER LEVER PLUNGER WITH PROTECTIVE BOOT HORIZONTAL ACTUATION	ROLLER LEVER Ø 18	VARIABLE LENGTH ROLLER LEVER Ø 18	VARIABLE LENGTH Ø 50 RUBBER ROLLER LEVER
Standard - Positive opening NC contacts	-	-	-	-
Minimum tripping force N	7	0.10	0.10	0.10
Minimum positive opening force N	24	0.32	-	-
Z11 Snap action 1NC-1NO	FT2P32Z11 	FT238Z11 	FT239Z11 	FT240Z11
X11 Slow break 1NC-1NO	FT2P32X11 	FT238X11 	FT239X11 	FT240X11
Y11 Slow break 1NC-1NO overlapping	FT2P32Y11 	FT238Y11 	FT239Y11 	FT240Y11
Z02 Snap action 2NC	FT2P32Z02 	FT238Z02 	FT239Z02 	FT240Z02
W02 Slow break 2NC	FT2P32W02 	FT238W02 	FT239W02 	FT240W02
W20 Slow break 2NO	FT2P32W20 	FT238W20 	FT239W20 	FT240W20

WEIGHT gr - MIN. PACK QTY.

105 gr 1 pcs 125 gr 1 pcs 125 gr 1 pcs 155 gr 1 pcs

DIMENSIONS

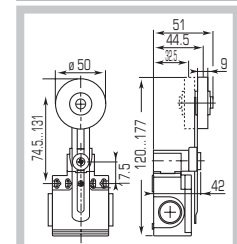
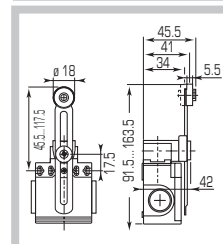
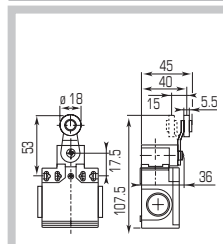
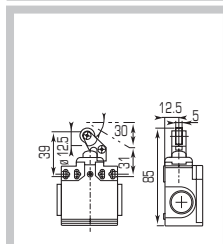
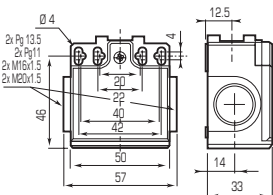

Limit Switches

Serie FT2

IP65 □ thermoplastic type

2 cable entries
M16x1.5



FT241



FT235



FT236



FT237

TYPE OF OPERATOR	Ø 50 RUBBER ROLLER LEVER	SPRING LEVER WITH TIP IN PA	"CAT'S WHISKER"	VARIABLE LENGTH Ø 3 STEEL ROD LEVER
Standard - Positive opening NC contacts	-	-	-	-
Minimum tripping force N	0.10	0.10	0.10	0.10
Minimum positive opening force N	-	0.32	-	-
Z11 Snap action 1NC-1NO	FT241Z11 	FT235Z11 	FT236Z11 	FT237Z11
X11 Slow break 1NC-1NO	FT241X11 	FT235X11 	FT236X11 	FT237X11
Y11 Slow break overlapping 1NC-1NO	FT241ZY11 	FT235Y11 	FT236Y11 	FT237Y11
Z02 Snap action 2NC	FT241Z02 	FT235Z02 	FT236Z02 	FT237Z02
W02 Slow break 2NC	FT241W02 	FT235W02 	FT236W02 	FT237W02
W20 Slow break 2NO	FT241W20 	FT235W20 	FT236W20 	FT237W20

WEIGHT gr - MIN. PACK QTY.

145 gr 1 pcs

135 gr 1 pcs

110 gr 1 pcs

130 gr 1 pcs

DIMENSIONS

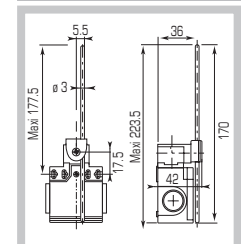
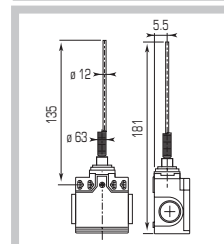
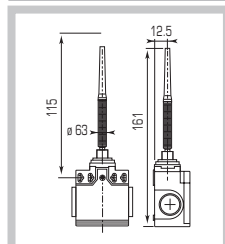
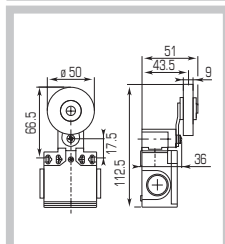
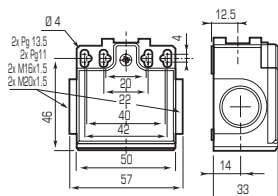

Limit Switches

FT1R Series with reset

IP65 □ thermoplastic type



AUTOMATION TECHNOLOGIES

1 cable entry
M16x1.5



FT1R31



FT1R34



FT1R32



FT1R33

TYPE OF OPERATOR	SHORT STEEL END PLUNGER	PA ROLLER PLUNGER	PA ROLLER LEVER PLUNGER HORIZONTAL ACTUATION	PA ROLLER LEVER PLUNGER VERTICAL ACTUATION
Standard - Positive opening NC contacts (→)	- (→)	- (→)	- (→)	- (→)
Minimum tripping force N	15	12	7	7
Minimum positive opening force N	30	30	24	24
Z11 Snap action 1NC-1NO	FT1R31Z11 0 13 25 41 56 mm	FT1R34Z11 0 25 47 76 96 mm	FT1R32Z11 0 49 90 145 210 mm	FT1R33Z11 0 49 90 145 210 mm
X11 Slow break 1NC-1NO	FT1R31X11 0 16 32 56 mm 2.5	FT1R34X11 0 32 60 96 mm 46	FT1R32X11 0 60 105 210 mm 86	FT1R33X11 0 60 105 210 mm 86
Y11 Slow break 1NC-1NO overlapping	FT1R31Y11 0 29 45 56 mm 15	FT1R34Y11 0 53 82 96 mm 30	FT1R32Y11 0 102 146 210 mm 54	FT1R33Y11 0 102 146 210 mm 54
Z02 Snap action 2NC	FT1R31Z02 0 13 24 40 56 mm	FT1R34Z02 0 25 45 74 96 mm	FT1R32Z02 0 51 86 131 210 mm	FT1R33Z02 0 51 86 131 210 mm
W02 Slow break 2NC	FT1R31W02 0 15 31 56 mm	FT1R34W02 0 30 59 96 mm	FT1R32W02 0 57 102 210 mm	FT1R33W02 0 57 102 210 mm

WEIGHT gr - MIN. PACK QTY.

75 gr

1 pcs

78 gr

1 pcs

80 gr

1 pcs

80 gr

1 pcs

DIMENSIONS

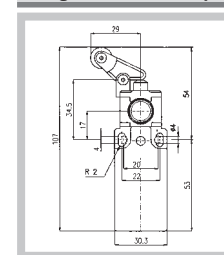
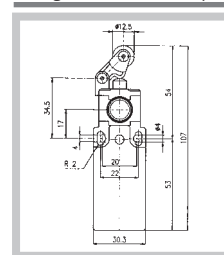
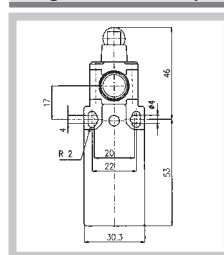
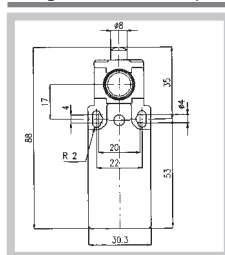
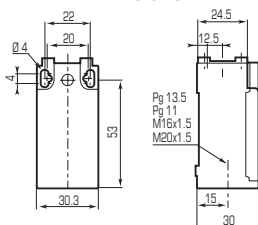

Limit Switches

FT1R Series with reset

IP65 □ thermoplastic type

1 cable entry
M16x1.5



FT1R38



FT1R41



FT1R39



FT1R40

TYPE OF OPERATOR	ROLLER LEVER Ø 18	Ø 50 RUBBER ROLLER LEVER	VARIABLE LENGTH ROLLER LEVER Ø 18	VARIABLE LENGTH Ø 50 RUBBER ROLLER LEVER
Standard - Positive opening NC contacts (→)	- (→)	-	-	-
Minimum tripping force N	0.10	0.10	0.10	0.10
Minimum positive opening force N	0.32	-	-	-
Snap action Z11 1NC-1NO	FT1R38Z11 	FT1R41Z11 	FT1R39Z11 	FT1R40Z11
Slow break X11 1NC-1NO	FT1R38X11 	FT1R41X11 	FT1R39X11 	FT1R40X11
Slow break Y11 1NC-1NO overlapping	FT1R38Y11 	FT1R41Y11 	FT1R39Y11 	FT1R40Y11
Snap action Z02 2NC	FT1R38Z02 	FT1R41Z02 	FT1R39Z02 	FT1R40Z02
Slow break W02 2NC	FT1R38W02 	FT1R41W02 	FT1R39W02 	FT1R40W02

WEIGHT gr - MIN. PACK QTY.

95 gr 1 pcs

110 gr 1 pcs

120 gr 1 pcs

145 gr 1 pcs

DIMENSIONS

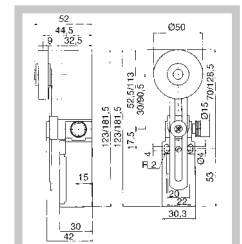
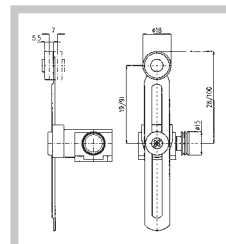
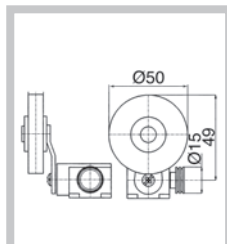
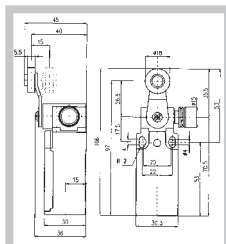
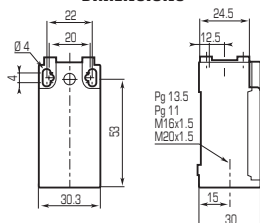

Safety Limit Switches

Safety Series - Limit Switches

IP65 □ thermoplastic type



AUTOMATION TECHNOLOGIES

1 cable entry
M16x1.5



ST1K1



ST1K61



ST1K71 Zinc Plated Steel Spindle
ST1K72 Stainless Steel Spindle



ST1K8

TYPE OF OPERATOR	90° ADJUSTABLE TURRET HEAD WITH ACTUATOR	ADJUSTABLE STEEL ROTARY LEVER	STEEL SPINDLE	360° ADJUSTABLE TURRET HEAD WITH ACTUATOR
Standard - Positive opening NC contacts (→)	- (→)	- (→)	- (→)	
Minimum tripping force N	-	-	-	-
Minimum positive opening force N	-	-	-	-
Z11 1NC-1NO 	ST1K1 * Z11	ST1K61Z11	Zinc Plated ST1K71Z11 Stainless ST1K72Z11	ST1K8 * Z11
X11 1NC-1NO 	ST1K1 * X11	ST1K61X11	Zinc Plated ST1K71X11 Stainless ST1K72X11	ST1K8 * X11
Y11 1NC-1NO overlapping 	ST1K1 * Y11	ST1K61Y11	Zinc Plated ST1K71Y11 Stainless ST1K72Y11	ST1K8 * Y11
Z02 2NC 	ST1K1 * Z02	ST1K61Z02	Zinc Plated ST1K71Z02 Stainless ST1K72Z02	ST1K8 * Z02
W02 2NC 	ST1K1 * W02	ST1K61W02	Zinc Plated ST1K71W02 Stainless ST1K72W02	ST1K8 * W02

WEIGHT gr - MIN. PACK QTY. 83 gr 1 pcs 96 gr 1 pcs 80 gr 1 pcs 90 gr 1 pcs

DIMENSIONS

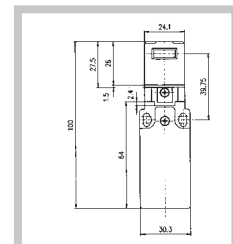
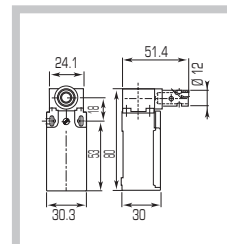
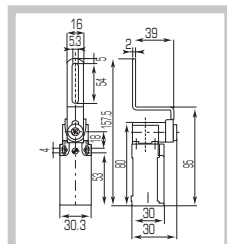
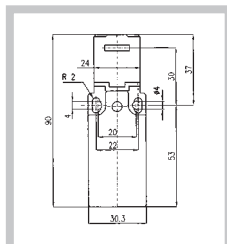

* Include actuator type reference number i.e.: ST1K13Z11

Safety Limit Switches

Safety Series - Limit Switches

IP65 □ thermoplastic type

ACTUATORS

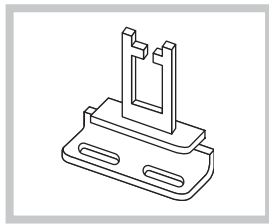

22MM RIGHT-ANGLED ACTUATOR

CODE

3

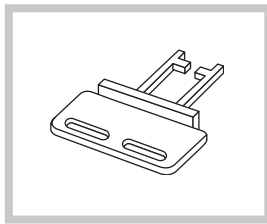

22MM STRAIGHT ACTUATOR

4

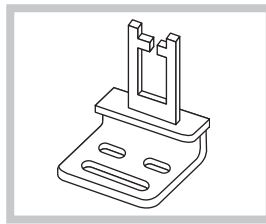

13MM RIGHT-ANGLED ACTUATOR

5

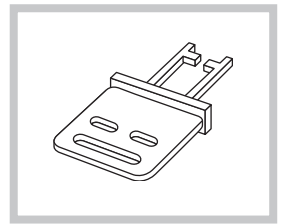

13MM STRAIGHT ACTUATOR

6

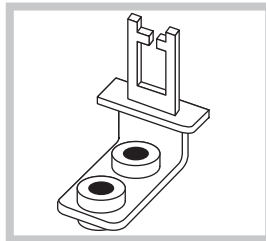

SHOCK ABSORBING RIGHT-ANGLED ACTUATOR

CODE

7

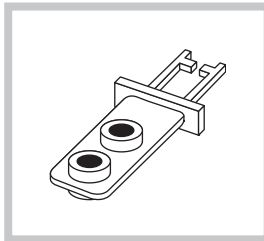

SHOCK ABSORBING STRAIGHT ACTUATOR

8

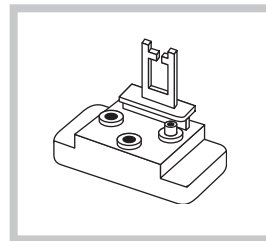

JOINTED KEY ACTUATOR

9

GENERAL CHARACTERISTICS

Safety limit switches are suitable for stopping dangerous machinery movements on opening of machine guards or protective covers. Available with different type of actuators and controls and with adjustable turret heads which can be rotated through 360° in 90° steps, they can be installed with a wide variety of opening mechanisms.

Comply with		IEC/EN60947-5-1, UL508		
Rated insulation voltage U_i	V	690		
Rated impulse withstand voltage U_{imp}	kV	6		
Operating frequency	Hz	50		
Rated thermal current I_{th}	A	10		
Rated operating current I_e :				
	V	24	230	380
AC15: alternate current	A	10	3.1	1.9
	V	24	250	-
DC13: direct current	A	2.8	0.27	-
Conditional short circuit withstand		10A gG fuse rating		
Electrical shocks withstand IEC 536		class II		
Protection rating IEC/EN 60529		IP65		
Operating temperature	°C	-25 +70		
Category of use UL 508		A600 - Q600		
Certifications		UL		

Limit Switches

FA - FT - FT1R Series

Installation and use



AUTOMATION TECHNOLOGIES

REVERSE MOUNTING OF THE OPERATING LEVER

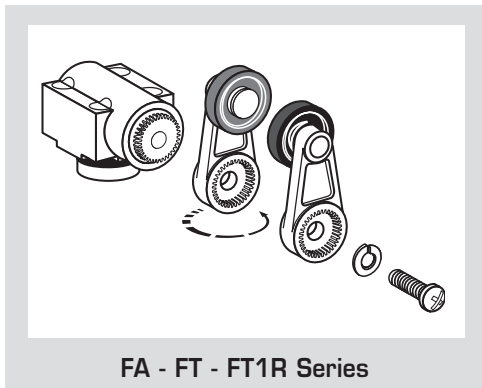

PLUNGER OR ROLLER LEVER

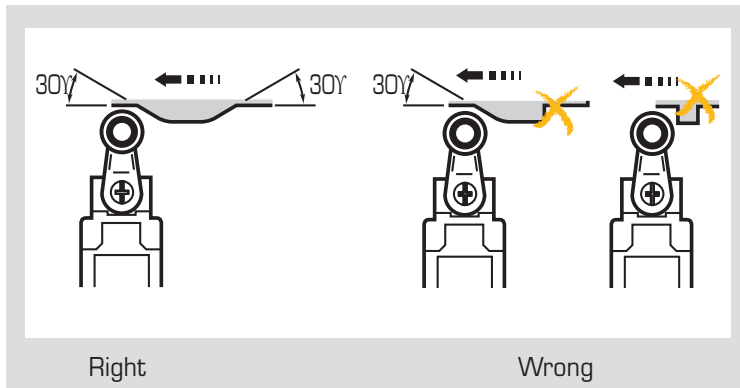

REST POSITION SETTING THROUGH 10° STEPS

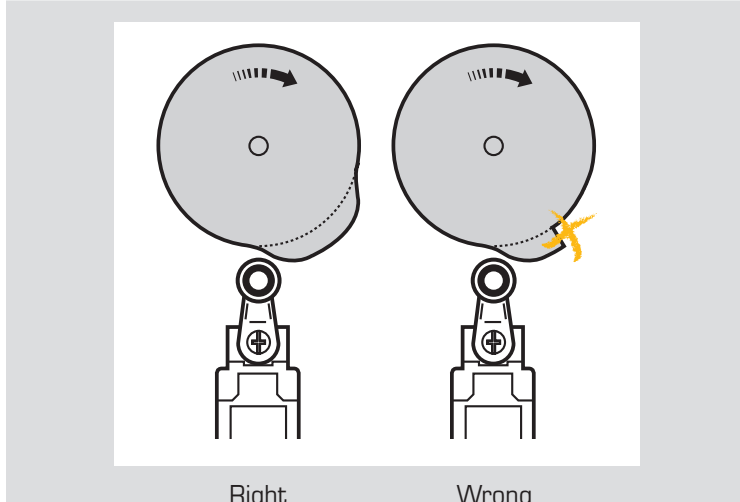
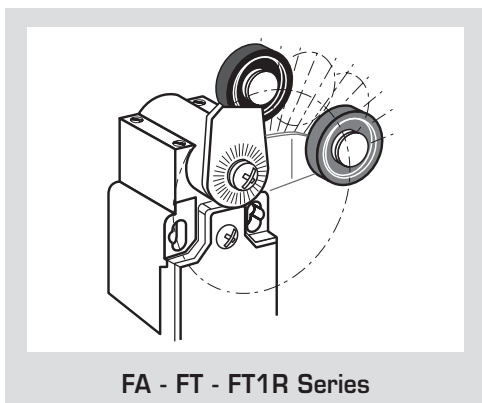

STEEL PLUNGER

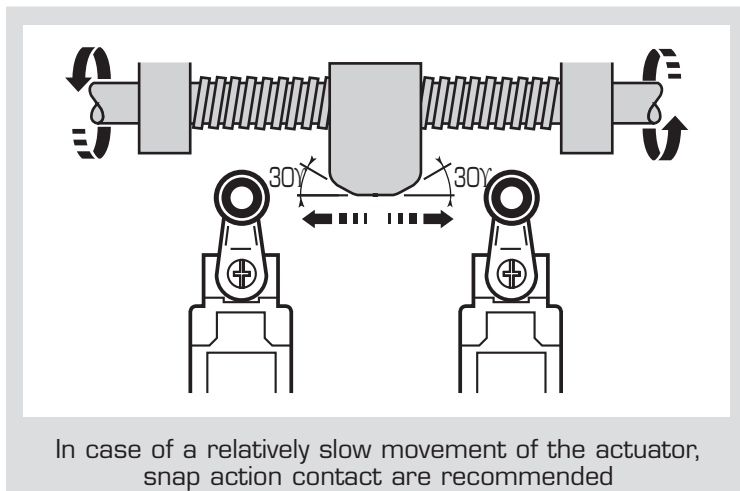
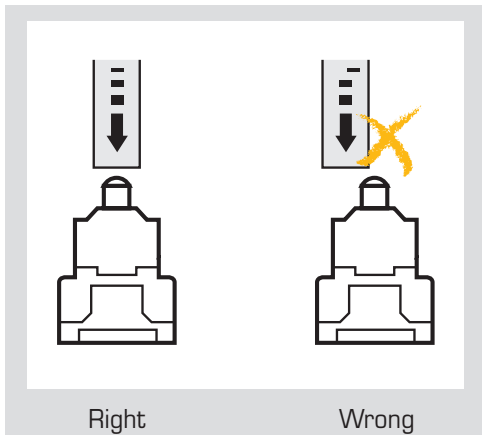

Limit Switches

FA - FT - FT1R Series

Technical data

GENERAL CHARACTERISTICS

Comply with	IEC947-5-1, EN60947-5-1, UL508, CSA 22.2 n° 14		
Certifications	cUL		
Ambient temperature	°C	Operating -25 +70	
	°C	Storage -30 +80	
Climate protection	IEC68 part 2-3	Hot damp	
	IEC68 part 2-11	Saline fog	
Installation positions	All positions		
Impact resistance	IEC68 part 2-27	50g* (1/2 sinusoidal shock for 11 msec) without replacing contacts	
Vibration resistance	IEC68 part 2-6	25g (10...500 Hz) without replacing contacts >100 msec	
Electrical shocks withstand	IEC536	Class II for FT series - Class I for FA series	
Protection rating	EN60529	IP65 FT series - IP66 - FA series	
Accuracy (measured after 1 million operations)	0.05 FA series - 0.1 FT series (on the making point)		
0.05 Minimum tripping force	m/s	Slow break 0.06 - snap action 0.001	
Rated insulation voltage Ui (IEC/EN60947-1)	V	690 FT series - 400 FA series	
according to UL508 and CSA C22-2 No. 14	V	(3 pollution grade)	
Rated impulse withstand voltage Uimp (IEC/EN60947-1)	kV	600 (designation A600 - Q600)	
Rated thermal current Ith (IEC/EN60947-1)	A	6	
Short circuit protection <500 Va.c. - fuses type gG (gl7)	A	10	
Rated operating current Ie: AC-15 (IEC/EN60947-5-1)	24 V - 50/60 Hz	A	10
	120 V - 50/60 Hz	A	6
	230 V - 50/60 Hz	A	3.1
	240 V - 50/60 Hz	A	3
	400 V - 50/60 Hz	A	1.9
	DC-13 (IEC/EN60947-5-1)	24 V - 50/60 Hz	A
	125 V - 50/60 Hz	A	0.55
	250 V - 50/60 Hz	A	0.27
Changeover frequency	cycles/hour	3600	
Load factor		0.5	
Contact insulation resistance	m Ω	25	
Termination type	M3.5 screw clamp terminals (+/-) pozidriv 2		
Earth terminal (FA series only)	M3.5 screw clamp terminals (+/-) pozidriv 2		
Terminal capacity solid/flexible conductor	n.1 o 2 x mm ²	0.75...2.5	
Terminal referencing	according to EN50013		
Mechanical life	milions of operations	15 FA. 31; 32; 33	
		10 FT. 34; 37; 38...41	
		>5 FT. P31...P33; 35; 36	
Electrical life (according to IEC/EN60947-5-1)	AC-15 and DC-13 categories of use (0.5 load factor according to the diagrams below)		

**AC-15
Snap
action**

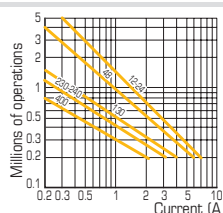

**AC-15
Slow
break**

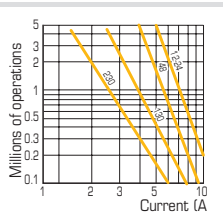

DC-13 Snap action Slow break

Breaking capacity for a duration of 5 millions cycles

Voltage 24 V	9.5 W	12 W
Voltage 48 V	6.8 W	9 W
Voltage 110 V	3.6 W	6 W

Limit Switches

Pre-wired FCT series

IP67 □ thermoplastic type



AUTOMATION TECHNOLOGIES

Cable: PVC UL
5x0.75 mm²
2 m length
Outlet: horizontal .L.
vertical .V.



.01.



.02.



.03.



.04.

TYPE OF OPERATOR	CABLE OUTLET	STEEL END PLUNGER	ROLLER PLUNGER	90° ROLLER PLUNGER	ROLLER LEVER Ø 14
X11 1NC-1NO 		FCT2L01X11	FCT2L02X11	FCT2L03X11	FCT2L04X11
		FCT2V01X11	FCT2V02X11	FCT2V03X11	FCT2V04X11
WEIGHT gr. - MIN. PACK QTY.		75 gr 1 pz	78 gr 1 pz	80 gr 1 pz	80 gr 1 pz
DIMENSIONS					

Cable: PVC UL
5x0.75 mm²
2 m length
Outlet: horizontal .L.
vertical .V.



.06.



.07.



.08.

TYPE OF OPERATOR	CABLE OUTLET	STEEL END PLUNGER WITH THREADED FLANGE	ROLLER PLUNGER WITH THREADED FLANGE	90° ROLLER PLUNGER WITH THREADED FLANGE	CHARACTERISTICS
X11 1NC-1NO 		FCT2L06X11	FCT2L07X11	FCT2L08X11	IEC/EN60947-5-1 Rated insulation voltage U _i /500V Rated thermal current I _{th} 10A Rated operating current I _e : AC15 U _e V 120 250 400 I _e A 6 4 3 DC13 U _e V 24 125 250 I _e A 2,5 0,55 0,27 UL508 General use Designation A300-Q300 Operating temperature -25 +70 °C Self extinguishing body VO
		FCT2V06X11	FCT2V07X11	FCT2V08X11	
WEIGHT gr - MIN. PACK QTY.		75 gr 1 pz	78 gr 1 pz	80 gr 1 pz	
DIMENSIONS					

Limit Switches

Pre-wired FCM series

IP67 Metal type



Cable: PVC UL
5x0.75 mm²
2 m length
Outlet: horizontal .L.



.01.



.02.



.03.



.04.

TYPE OF OPERATOR	STEEL END PLUNGER	ROLLER PLUNGER	90° ROLLER PLUNGER	14 Ø POM ROLLER LEVER
<p>Slow break</p> <p>Z11 1NC-1NO</p>	<p>FCM2L01Z11</p>	<p>FCM2L02Z11</p>	<p>FCM2L03Z11</p>	<p>FCM2L04Z11</p>
WEIGHT gr - MIN. PACK QTY.	175 gr 1 pz	180 gr 1 pz	180 gr 1 pz	225 gr 1 pz
DIMENSIONS				



Cable: PVC UL
5x0.75 mm²
2 m length
Outlet: horizontal .L.



.06.



.07.



.08.

TYPE OF OPERATOR	STEEL END PLUNGER WITH THREADED FLANGE	ROLLER PLUNGER WITH THREADED FLANGE	90° ROLLER PLUNGER WITH THREADED FLANGE	CHARACTERISTICS																				
<p>Slow break</p> <p>Z11 1NC-1NO</p>	<p>FCM2L06Z11</p>	<p>FCM2L07Z11</p>	<p>FCM2L08Z11</p>	<p>IEC/EN60947-5-1 Rated insulation voltage Ui/500V Rated thermal current Ith 5A Rated operating current Ie:</p> <table border="1"> <tr> <td>AC15</td> <td>Ue V</td> <td>24</td> <td>120</td> <td>240</td> </tr> <tr> <td></td> <td>Ie A</td> <td>5</td> <td>3</td> <td>1,5</td> </tr> <tr> <td>DC13</td> <td>Ue V</td> <td>24</td> <td>125</td> <td>250</td> </tr> <tr> <td></td> <td>Ie A</td> <td>1</td> <td>0,22</td> <td>0,1</td> </tr> </table> <p>Pollution class 3 Material group I Operating temperatures -25 +70 °C</p>	AC15	Ue V	24	120	240		Ie A	5	3	1,5	DC13	Ue V	24	125	250		Ie A	1	0,22	0,1
AC15	Ue V	24	120		240																			
	Ie A	5	3		1,5																			
DC13	Ue V	24	125		250																			
	Ie A	1	0,22	0,1																				
WEIGHT gr - MIN. PACK QTY.	75 gr 1 pz	78 gr 1 pz	80 gr 1 pz																					
DIMENSIONS																								

Limit Switches

Astra Series

IP54 universal type



AUTOMATION TECHNOLOGIES

2 cable entries
with cable gland



TYPE OF OPERATOR	STEEL ROLLER PLUNGER	ROLLER LEVER Ø 20	ROLLER LEVER Ø 35	ROLLER PLUNGER AND LEVER WITH RESET
1NC-1NO Slow break 	30303061 	30303073 	30303025 	30303092 lever
1NC-1NO overlapping Slow break 	30303062 	30303074 	30303026 	30303098 with plunger
WEIGHT gr - MIN. PACK QTY.	130 gr 1 pz	160 gr 1 pz	200 gr 1 pz	180 gr 1 pz
DIMENSIONS				

GENERAL CHARACTERISTICS

Comply with	IEC/EN60947-5-1						
Rated insulation voltage U_i	500 (pollution class 3)						
Rated impulse withstand voltage U_{imp}	4						
Operating frequency	50/60						
Rated thermal current I_{th}	10						
Rated operating current I_e : AC-15 alterante current	<table border="1"> <tr> <td>110</td> <td>230</td> <td>380</td> </tr> <tr> <td>8</td> <td>8</td> <td>6</td> </tr> </table>	110	230	380	8	8	6
110	230	380					
8	8	6					
Contact type	Slow break double gap contacts						
Protection rating	IP54						
Ambient temperature	Operating -25 +55 Storage -30 +70						
Termination type	Screw clamp terminals						
Materials	Housing in reinforced PA - PC lid Nickel brass plunger - Reinforced PC lever						



GIOVENZANA INTERNATIONAL B.V.

WTC Strawinskylaan 1105, 1077 XX Amsterdam, The Netherlands
Ph. +31(0)20.4413576 - Fax +31(0)20.4413456 - e-mail: giovenzana@giovenzana.com
G.M.K. K.f.t. - 1068 Budapest - Hungary - Rippl Ronai ut. 13
Ph. +36.37.572575 - Fax +36.37.572570 - e-mail: gmk@giovenzana.com

BRANCH

DUBAI U.A.E. P.o. Box 262146
Jafza 17, Ali Free Zone
Ph. +971.4.8870788
Fax +971.4.8870787

MOSCOW Russian Federation
Ulitsa Radio 24 - Yauza Tower 4th floor
Ph. +7.495.6991296 - 6503959
Fax +7.495.6991520

www.giovenzana.com